

LED Luminous Virtual Window Surface Mount Installation Instructions (V~/Non-MRI)*



Installation packet includes:

- LED Luminous Virtual Window Surface Mount Installation Instructions (V~/Non-MRI)
- LED Luminous Virtual Window Technical Specifications
- LED Luminous Virtual Window Maintenance

Read the installation instructions thoroughly before removing LVW from crate and beginning installation.

For technical support at any time during the installation, please call us toll free at 866-759-3228. We want your installation to go as smoothly as possible. Thank you for choosing The Sky Factory.

* V~ refers to Volts of Alternating Current (AC); V== refers to Volts of Direct Current (DC)

LVW Components and Installation Hardware Provided:

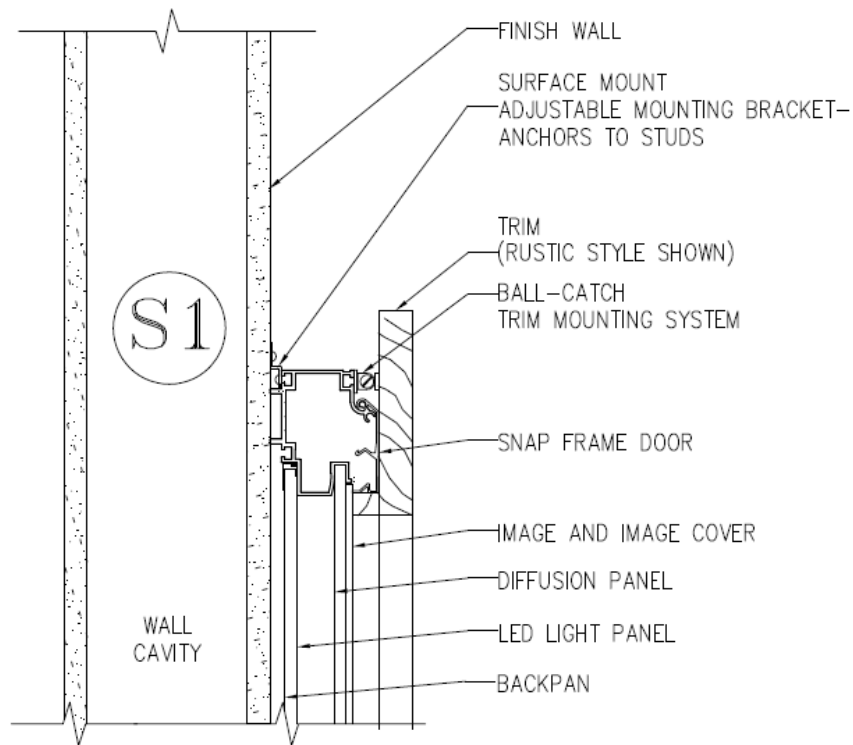

Dimensions: 2 3/8" (60mm) front to back without the trim.

For outside dimensions, see LVW Dimensions Chart on page 11. Trim dimension varies with material and style.

LVW Case: extruded aluminum frame, four snap-frame doors, aluminum back pan, light panel, diffusion panel, two or more internal power supplies, wiring covers and safety cables.

Image Panel: .017" (.439mm) sandwich of 6 mil backlit film with a protective UV laminate.

Image Cover: .125" (3.175mm) non-glare acrylic panel which serves as a protective cover for the image panel.

Trim: Wood or anodized aluminum frame which attaches to the LVW case with ball catches and safety cables; side panels which attach to the LVW case with brackets and #6 nuts.

Installation Hardware: 1/2" (12.7mm) box connector, 4 – 8 mounting brackets, 4 – 8 #10 x 2" (51mm) or #12 x 2" (51mm) pan head screws, and 1/16" hex wrench.

Provided by the Installer:

Electrical circuit, V~ switch, conduit (if required) and wiring appropriate to local code provided and run to the appropriate locations.

Tools Needed by the Installer:

Tape measure

4' (1219mm) carpenter's level

Driver/drill

Phillips bit with at least a 2" (50mm) bit holder

Drill

1/8" (4mm) drill bit

5/16" (8mm) open end wrench

Phillips and straight blade screw drivers

Needle nose pliers

Quick release tape

A clean flat surface to lay the LVW case on

Step 1: Removing an LVW from the crate

Some LVW's are held in place inside the crate with 3/4" (19mm) x 6" (152mm) plywood battens. If so, remove the battens by removing the screws holding the battens down to ledgers along the sides of the crate.

If the LVW includes trim, the LVW is shipped with the trim attached. The trim must be removed before removing the LVW from the crate. The trim is held to the LVW case with ball catches. **To remove the trim**, grasp it along the sides with both hands and pull it directly away from the face of the LVW case.

The LVW case is wedged into the crate with styrofoam blocks. Remove the blocks and lift the LVW out of the box **without overly twisting or torquing the frame:**

The LVW is not a rigid structure, and has some built in flexibility.

However, excessive twist could damage the light panel.

Side panels and installation hardware are shipped above or along one side of the LVW(s) in the crate.

Step 2: Locating the LVW on the Wall

See Luminous Virtual Window Dimensions Chart on page 11 for all standard LVW dimensions. For Custom, Twin and Triple LVW installations, see drawing "LVW1" for suggested spacing.

We recommend the LVW is placed at standard window height. For surface mount installations, two installers are recommended.

Where possible, place the LVW so it can be anchored to at least two studs. The attachment brackets are adjustable, and can travel from 2 1/4" (57mm) in from the left corner to 2 1/4" (57mm) in from the right corner. See "Step 5: Locating the Mounting Brackets" on page 6.

In some 22/40 LVW installations, attachment to two studs may not be possible. A minimum of one solid attachment point at the top and one at the bottom is required. A 3/16" (9.5mm) toggle bolt may be used in the other attachment bracket at the top and bottom. **All larger sizes require at least two solid attachment points at top and bottom.**

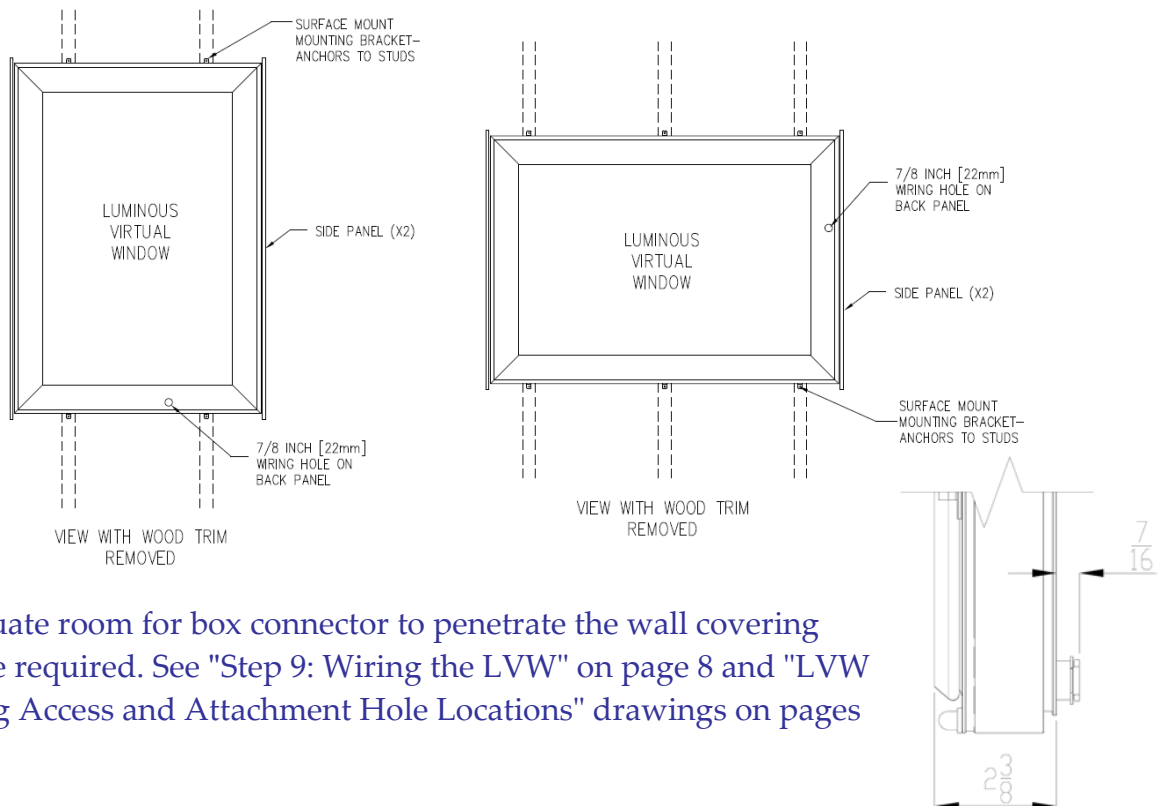

Adequate room for box connector to penetrate the wall covering will be required. See "Step 9: Wiring the LVW" on page 8 and "LVW Wiring Access and Attachment Hole Locations" drawings on pages 12-13.

Using quick-release tape, mark the top and bottom outside edges of the LVW case and the attachment points on the wall.

Step 3: Checking the Mounting Location for Flatness

IMPORTANT: If the wall is too uneven, the LVW may need to be shimmed at one or more of the mounting bracket locations.

Any excessive twist in the installed LVW frame may keep some of the ball catches from latching and allow the trim to pop loose.

See "Appendix A: Checking for Flatness" on page 14 for determining if the LVW will sit in a flat plane.

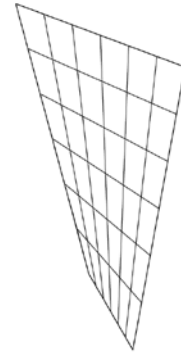

Step 4: Preparing the LVW for Installation

Remove the trim (if provided): The trim is held by ball-catch hardware. Make sure the safety cables are not connected. Then, using both hands, grasp the trim and pull it directly away from the LVW case.

Image panel and non-glare acrylic image cover do not need to be removed for installation:

If image panel and image cover are not removed, always keep at least two doors closed during installation (or when LVW is vertical) to hold image panel and image cover in place.

Caution: image cover scratches easily and scratches show up when the LVW is lit. (If the image panel and cover are removed, see the "LVW LED Maintenance" document for instructions on how to re-install them.)

To open the snap-frame doors: Electrical entry and attachment holes are behind the doors. To open a door, hook a thumb in the v-groove on the inside edge of the door, gently slide the door toward the outside edge of the LVW, then flip the door up and out.

To remove wiring covers: Electrical entry and attachment holes are behind wiring covers. See "Step 10: Wiring the LVW" on pages 8-9.

Insert the box connector: Make sure power is available and is going to enter the LVW at the proper location. See "Step 10: Wiring the LVW" and "LVW Wiring Access and Attachment Hole Locations" drawings on pages 12-13.

Step 5: Positioning the Mounting Brackets

Four to eight brackets are provided with each LVW. The brackets mount to adjustable set screws located in a slot along the back outside edge of the aluminum frame, top and bottom.

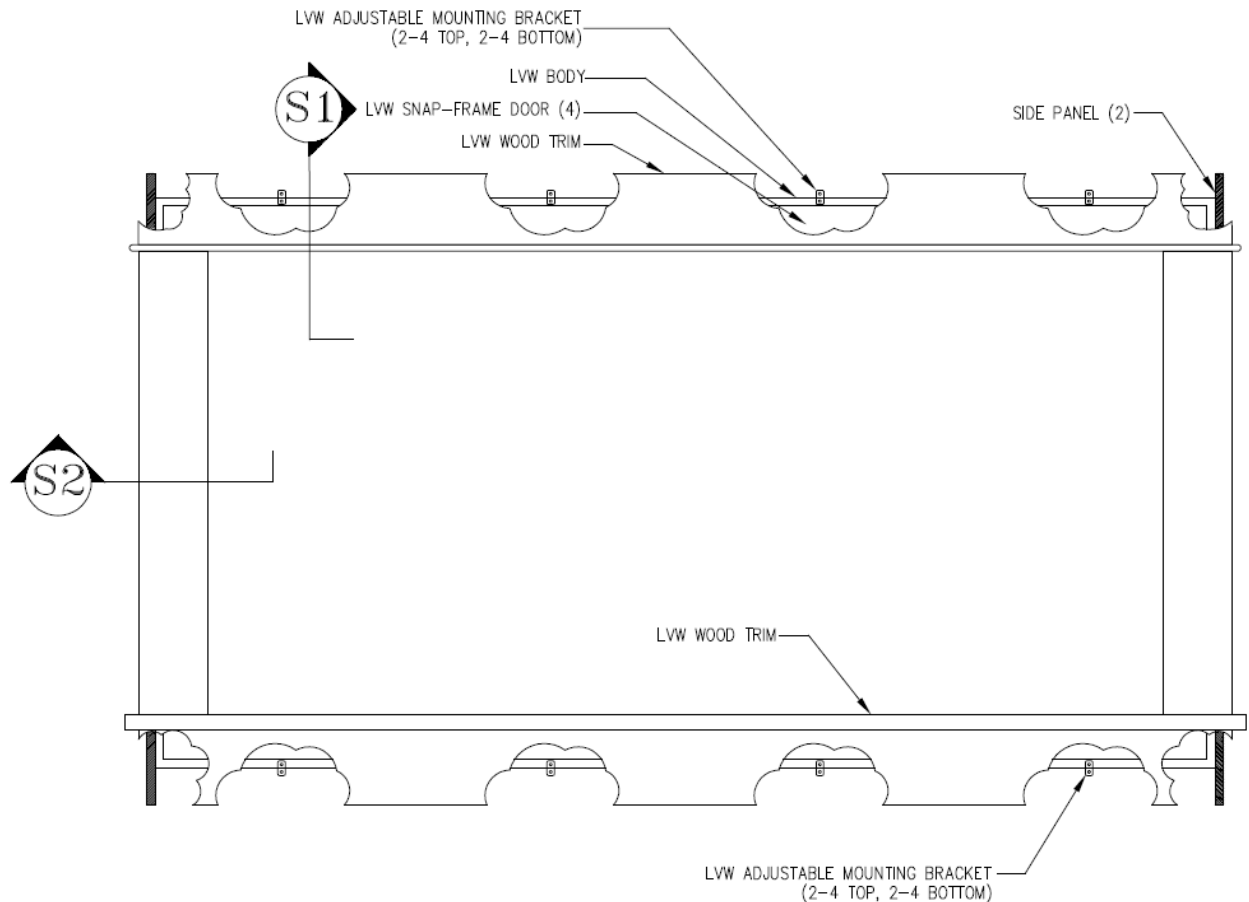

Arts and Crafts Style Wood Trim Shown

Ⓢ1 on page 2. Ⓢ2 on page 7.

Brackets must be attached to solid backing. With 22/40 LVWs, when only one framing member is available, a 3/16" toggle for the second bracket on top and bottom is acceptable. See "Step 2: Locating the LVW on the Wall".

The mounting range varies with the size of the LVW, and can be set anywhere between 2 1/4" (57mm) in from the left corner to 2 1/4" (57mm) in from the right corner. See LVW Dimensions Chart on page 10.

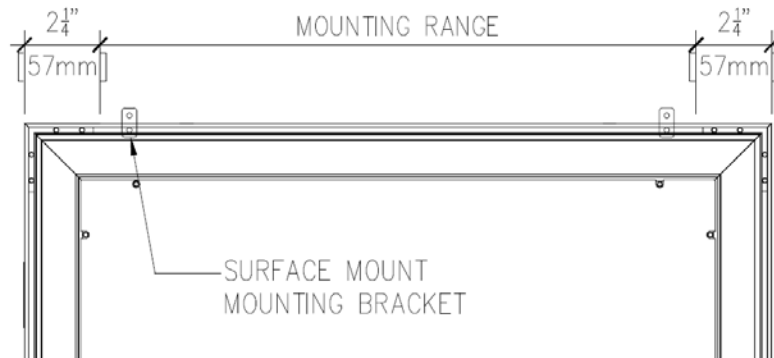

Back of LVW Shown

To set the brackets and install the side panels, the LVW must set face down with all the doors closed on a flat protected surface.

To locate a bracket, use a 5/16" (8mm) open wrench to remove the locking nut from a set screw. Then loosen the screw with the 1/16" hex wrench provided, slide it to the appropriate location, and re-tighten it. Once the set screw is properly located, attach the mounting bracket to it with the locking nut.

Step 6: Attaching the Side Panels

Side panels must be attached before installing the LVW. Left panel is labeled **Top Left**. Right panel is labeled **Top Right**.

Example illustrates wood side panel. Aluminum side panel mounts in the same way.

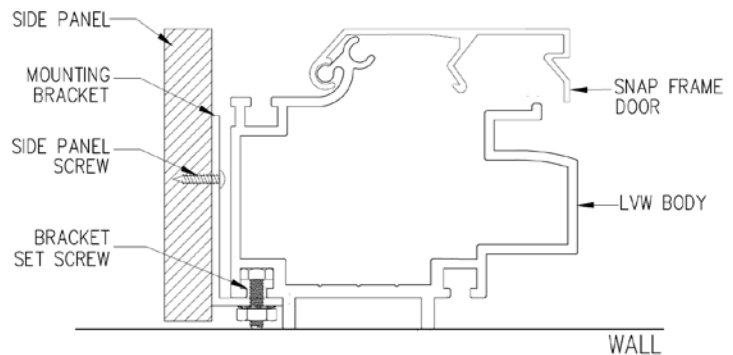

(S2) With Wood Trim Removed

Set screws and locking nuts for mounting the side panels are located in a slot along the back outside edge of the aluminum frame on both sides. The set screws are pre-installed at the factory to their correct locations. Remove the nuts, insert the appropriate side panel onto the screws and re-attach the nuts.

Step 7: Attaching the LVW to the Wall

Because power cable must be run into the LVW while installing it to the wall, two installers are recommended.

Use the #10 x 2" (51mm) or #12 x 2" (51mm) pan head screws provided. If pilot holes need to be drilled, hold the LVW up, mark the attachment holes, then set it aside and pre-drill the holes before running power into the case.

Open the bottom door. With one person holding the LVW, the other passes the power cable through the box connector and then screws the LVW to the wall.

IMPORTANT: Before fully tightening the screws, make sure the LVW case will sit against the wall without excessive twist. See "Step 3: Checking the Mounting Location for Flatness".

Step 9: Wiring the LVW

See "LVW Wiring Access and Attachment Hole Locations" drawings on pages 12-13.

IMPORTANT:

**The lights in the fixture are V \equiv powered LED's.
Only connect the V \sim Line and Neutral Inputs
to the Screw Type, Barrier Style Terminal Block
mounted inside the frame.
Connecting the V \sim input to any other type of connector
in the fixture will destroy the LED's.**

Each LVW has internal 24 V \equiv power supplies pre-wired at The Sky Factory.

- Power supplies are 100-240 V \sim /277 V \sim , 0.3A/0.105A, 50/60 Hz. See "LVW Technical Specifications" for amperages of individual units.

V~ power is connected to the power input terminal block – line power to L1, neutral to N. Ground is connected to green Earth Ground screw, .

Terminal block wire range is #12 - 22 AWG.

A wiring cover must be removed to access power input terminal block. When replacing the cover, make sure the door ground wire falls in the slot and that all mounting screws are tight.

Always turn circuit off before removing a wiring cover.

Fasten the provided 1/2" (12.7mm) box connector (or comparable) in the 7/8" (22mm) electrical entry hole and make the electrical connection inside the LVW.

Connect power (100 – 240V~/277V~) in conformance to local and national Electrical Codes.

**IN MRI APPLICATIONS, AN RF FILTER IS REQUIRED
AND WILL BE SUPPLIED BY OTHERS.**

Step 10: Installing the LVW Trim

To install the LVW trim, close all four doors.

Safety cables: Safety cables are provided to catch the LVW trim if it is accidentally jarred loose of the ball catches. Attaching the safety cables is easiest with two people. Have one person lift the trim up so the eye screws in the back of the trim are at the same height as the safety cables on the LVW frame. Have the second person attach the quick links to the eyes and screw the gates closed.

Once the safety cables are attached, lower the trim until the two sides of the ball-catches line up and then press the trim against the LVW frame into the ball-catches latch.

To adjust holding strength of a ball catch: Loosen or tighten adjustment screws on the two ends of the half attached to the LVW frame.

To adjust the location of a ball catch: Location of the ball catches should not need to be adjusted in the field. If, however, the location of a catch needs to be adjusted, loosen the nuts holding it down using a 5/16" (8mm) open end wrench, then loosen the set screws and slide them with the ball catch to the appropriate location in the track. Then re-tighten the set screws, and re-tighten the nuts holding the ball catch to the LVW case.

LUMINOUS VIRTUAL WINDOW

DIMENSIONS CHART

LUMINOUS VIRTUAL WINDOW	ACTUAL FRAME DIMENSIONS (INCHES)	ACTUAL FRAME DIMENSIONS (MM)
22/40	22 1/4 / 40 1/4	565 / 1022
40/22	40 1/4 / 22 1/4	1022 / 565
28/40	28 1/4 / 40 1/4	718 / 1022
40/28	40 1/4 / 28 1/4	1022 / 718
34/40	34 1/4 / 40 1/4	870 / 1022
40/34	40 1/4 / 34 1/4	1022 / 870
26/52	26 1/4 / 52 1/4	667 / 1327
28/52	28 1/4 / 52 1/4	718 / 1327
52/28	52 1/4 / 28 1/4	1327 / 718
42/52	42 1/4 / 52 1/4	1073 / 1327
52/42	52 1/4 / 42 1/4	1327 / 1073
18/64	18 1/4 / 64 1/4	464 / 1632
64/18	64 1/4 / 18 1/4	1632 / 464
34/64	34 1/4 / 64 1/4	870 / 1632
64/34	64 1/4 / 34 1/4	1632 / 870

For Custom, Twin and Triple Installations, See Drawing LVW1 for Dimensions, Rough Opening and Suggested Spacing Where Applicable.

REVISIONS			
REV.	DESCRIPTION	DATE	APPROVED
B	MOVED ELEC. ENTRY HOLE AND ADDED NOTE ON CONDUIT SIZE	11/17/2011	JE

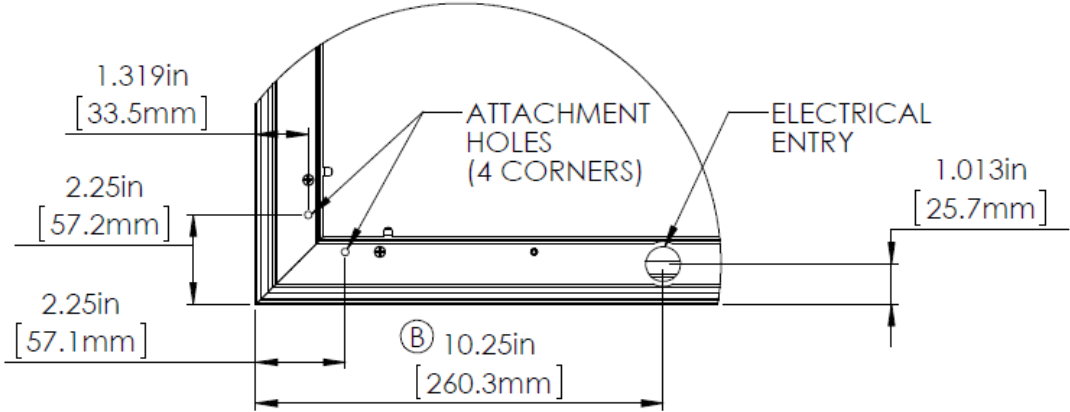
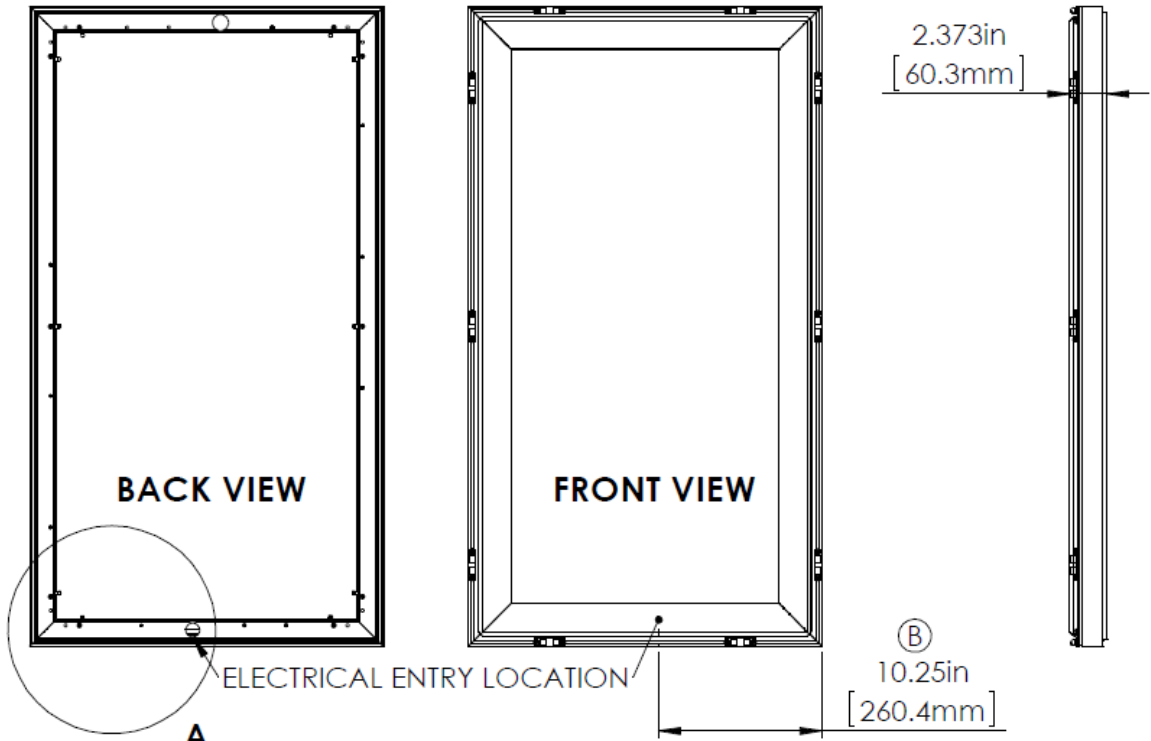

**DETAIL A
SCALE 1 : 4**

NOTE: ELECTRICAL ENTRY HOLE LIMITED TO 1/2" NOMINAL TRADES SIZE CONDUIT

PROPRIETARY AND CONFIDENTIAL
THE INFORMATION CONTAINED IN THIS DRAWING IS THE SOLE PROPERTY OF THE SKY FACTORY. ANY REPRODUCTION IN PART OR AS A WHOLE WITHOUT THE WRITTEN PERMISSION OF THE SKY FACTORY IS PROHIBITED.

		DIMENSIONS ARE IN INCHES TOLERANCES: FRACTIONAL ± ANGULAR: MACH ± BEND ± TWO PLACE DECIMAL ±0.010 THREE PLACE DECIMAL ±0.005	DRAWN JE 12/16/2011	NAME DATE
		MATERIAL \$PRPSHEET-(Material)	CHECKED	
		FINISH	ENG APPR.	
NEXT ASSY	USED ON		MFG APPR.	
			Q.A.	
APPLICATION	DO NOT SCALE DRAWING		COMMENTS:	

LVW WIRING ACCESS AND ATTACHMENT HOLE LOCATIONS, VERTICAL ORIENTATION

SIZE A	DWG. NO. IM000017	REV. B
------------------	----------------------	------------------

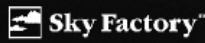

REVISIONS				
ZONE	REV.	DESCRIPTION	DATE	APPROVED
-	B	See VERTICAL	-	-

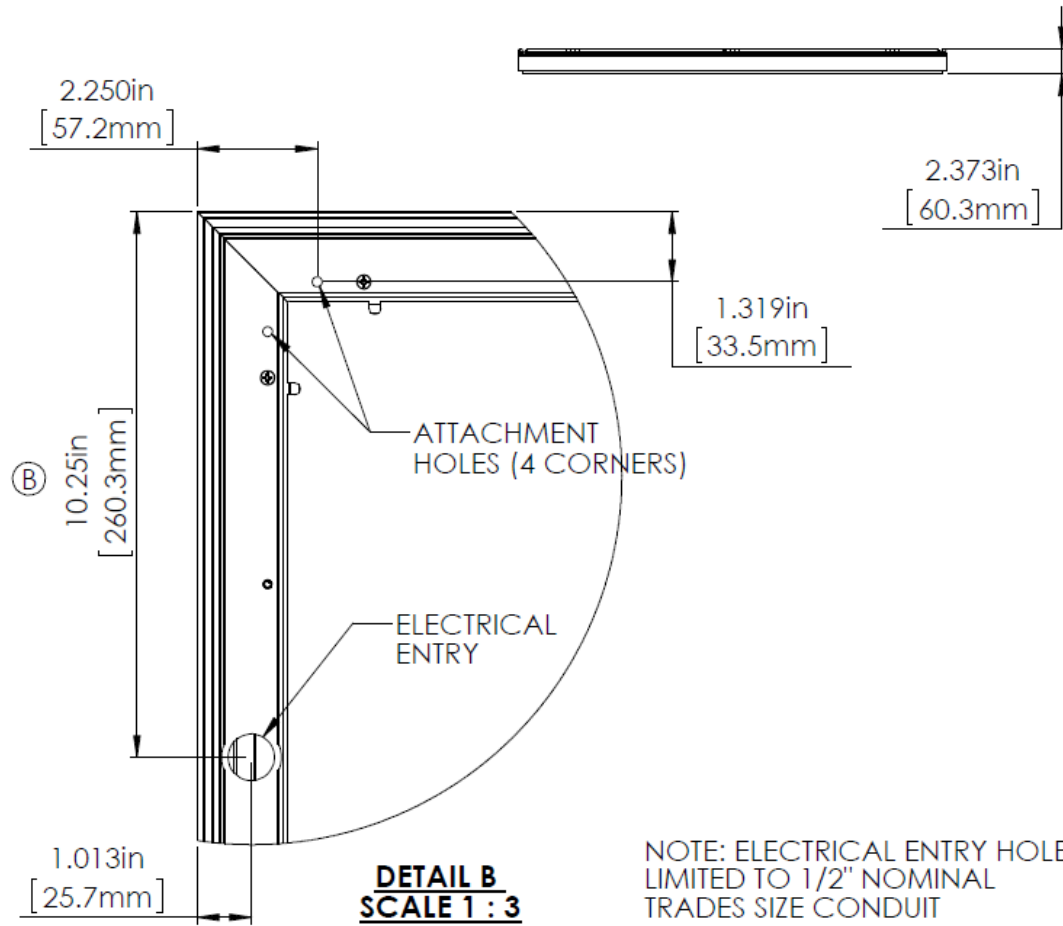
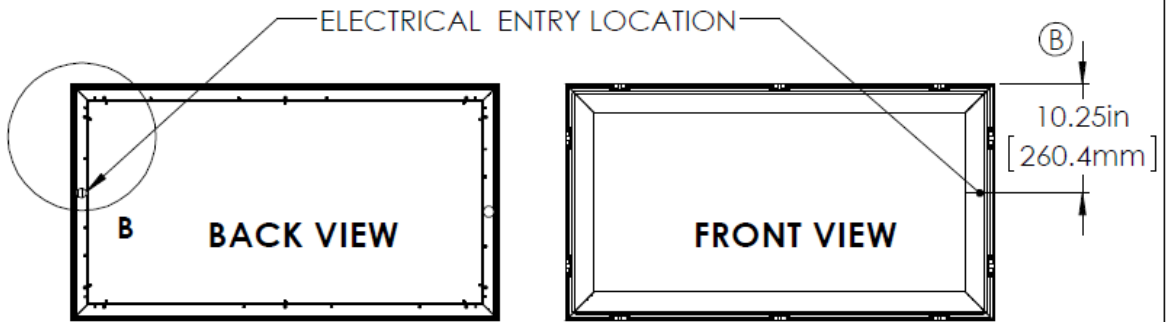

DETAIL B
SCALE 1 : 3

NOTE: ELECTRICAL ENTRY HOLE LIMITED TO 1/2" NOMINAL TRADES SIZE CONDUIT

<p>PROPRIETARY AND CONFIDENTIAL</p> <p>THE INFORMATION CONTAINED IN THIS DRAWING IS THE SOLE PROPERTY OF THE SKY FACTORY. ANY REPRODUCTION IN PART OR AS A WHOLE WITHOUT THE WRITTEN PERMISSION OF THE SKY FACTORY IS PROHIBITED.</p>	<p>DIMENSIONS ARE IN INCHES</p> <p>TOLERANCES:</p> <p>FRACTIONAL ±</p> <p>ANGULAR: MACH ± BEND ±</p> <p>TWO PLACE DECIMAL ±0.010</p> <p>THREE PLACE DECIMAL ±0.005</p>		<p>NAME</p> <p>JE</p>	<p>DATE</p> <p>11-17-2011</p>	<p>LVW WIRING ACCESS AND ATTACHMENT HOLE LOCATIONS, HORIZONTAL ORIENTATION</p>
	<p>MATERIAL</p> <p>\$PPPSHEET:(Material)</p>	<p>DRAWN</p>	<p>CHECKED</p>	<p>ENG APPR.</p>	
	<p>FINISH</p>	<p>MFG APPR.</p>	<p>Q.A.</p>	<p>COMMENTS:</p>	
	<p>NEXT ASSY</p> <p>USED ON</p> <p>APPLICATION</p>	<p>DO NOT SCALE DRAWING</p>	<p>SEE</p> <p>A</p>	<p>DWG. NO.</p> <p>IM000017</p>	
		<p>Sky Factory</p>		<p>WEIGHT:</p>	<p>SHEET 2 OF 2</p>

Appendix A: Checking For Flatness

Making Sure the LVW Will Sit in a Single Plane:

Hold a builder's level against the wall to make sure the two vertical sides have equal plumb.

NOTE: The window does not have to sit plumb on the wall to function properly, but must sit in a single plane, which means the bubble on the builder's level must read the same for both vertical sides. See below.

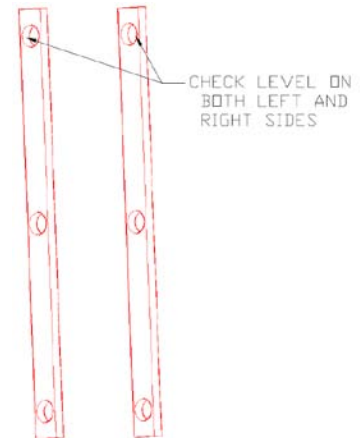

If the two sides do not read the same, shim out one or more of the attachment brackets so they do.

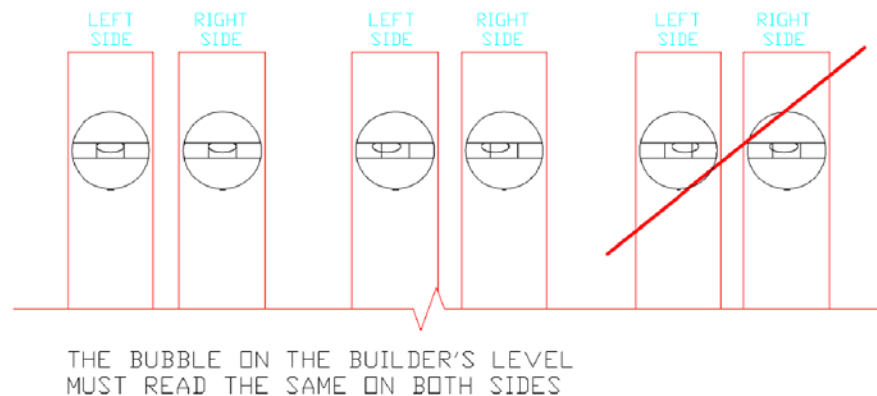

Making Sure the LVW Is Sitting in a Single Plane:

Use a builder's level against the face of the doors to make sure the two vertical sides have equal plumb. Shim if necessary. See Step 5.

NOTE: Make sure the doors are completely closed before checking for equal plumb.